

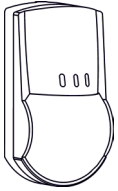

# PASSIVE INFRARED VERTICAL CURTAIN DETECTOR

## «FOTON-16B» WITH ANTIMASKING FUNCTION

### Installation Guide



#### 1 General Information

1.1 Passive infrared vertical curtain detector «Foton-16B» (hereinafter, the Detector) is designed for detecting intrusion into a protected space and generating an alarm message.

1.2 Ambient class: Boreal climate.

1.3 The Detector is designed to operate continuously around the clock.

1.4 The Detector does not produce any interferences to other detectors of the same or other type and designation, as well as to any domestic radio equipment.

#### 2 Features

- Active infrared channel with antimasking function.
- Possibility of saving of the Detection channel masking parameters into nonvolatile memory.
- Two-color LED indication with a possibility of it's disabling.
- Self-testing mode.
- Immunity to insect's intrusion to the pyrodetector.
- Swivel bracket (supplied) providing ease of the Detector installation and detection zone repositioning.

#### 3 Specifications

Parameter	Value
Detection range, maximum	15 m
Maximum antimasking detection range, not less than	0.1 m
Power supply	9 ... 15 V DC
Consumption current, not more than	35 mA
Alarm message duration, not less than	4 sec
Operation temperature	minus 30 ... +55 °C
Relative humidity under +25 °C without moisture condensation, up to	98 %
IP rating	IP41
Dimensions, maximum	126 x 70 x 55 mm
Mass, maximum	150 g
Average service life, not less than	8 years

Detection zone pattern is shown in Figure 1.

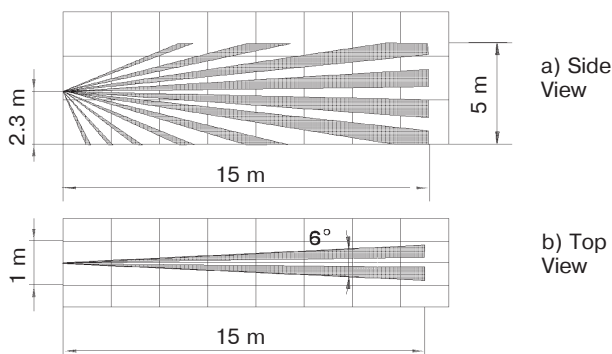

Figure 1 – Detection Zone Pattern

#### 4 Scope of delivery

Name	QNT
Passive infrared vertical curtain detector «Foton-16B»	1 pc.
Swivel bracket	1 pc.
Screw 3-3x30.016	2 pcs.
Passive infrared vertical curtain detector «Foton-16B». Installation Guide	1 copy

#### 5 Installing the Detector

Recommended mounting height of the Detector is 2.3 m above the floor. The shape of the Detector base allows to mount the Detector on the wall, as well as in the corner of the room. In case of the swivel bracket usage (supplied), the Detector can be installed on the wall or ceiling at a height 2.3 ... 3 m above the floor. Swivel bracket construction provides detection zone repositioning.

When choosing the Detector installation place, take note of the fact that the detection zone may be limited by non-transparent objects (curtains, houseplants, cabinets, bookcases, etc.), as well as glass and mesh partitions. There must be no windows, air conditioners, space heaters or heating radiators in the Detector visibility range.

#### The Detector installation:

5.1 Unfasten the latch through the opening (5), which is situated downside the detector case by means of screwdriver and put off the detector cover.

5.2 Put off the PCB by means of pushing up it's fixing arm (4) on the base.

5.3 Drill the holes (1) for wiring and fastening the Detector:

- for wall mounting – holes (6);
- for corner mounting – holes (3).

5.4 Pass the wire through the mounting holes (1) and fasten the base on the wall (corner) by screws.

5.5 If swivel bracket is used for installation:

- open hole (2);
- insert a nut (8) to the sphere bulge (9);
- insert a sphere (9) and then a bush (7) to the base of the swivel bracket (11).

Fasten an assembled swivel bracket on the wall (ceiling) by screws. Pass the wires and tighten the base on the swivel bracket by the screw (12). Fix position of the sphere when tightening the screw (12).

5.6 Put PCB on it's place.

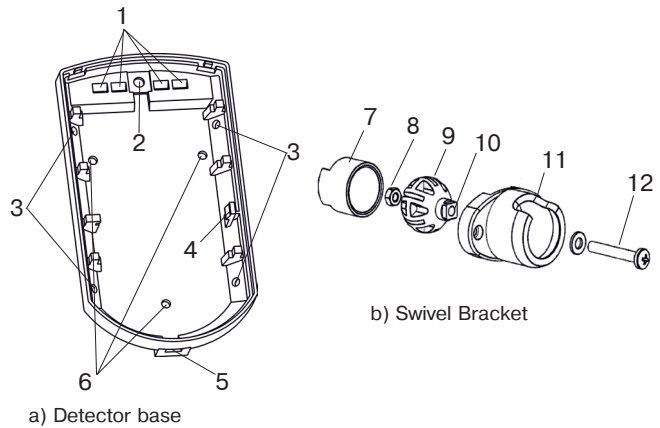

Figure 2 – Detector Base and Swivel Bracket

**Note** – Places for mounting holes on the installation surface can be marked using a detector base with opened holes as a pattern.

#### 6 The Detector Hooking up

Marked terminals for the Detector hooking up are located at the top of the PCB (See Figure 3).

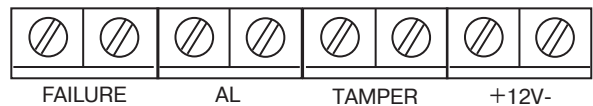

Figure 3 – Terminals for hookup wire connection

Connection of the Detector to the control panel (CP) should be fulfilled in accordance with CH Installation Guide.

#### 7 The Detector Adjustment

The Detector adjustment should be realized by changing position of «1», «2», «3», «4» and «5» DIP-switches, located at the top of PCB. DIP-switch «1» changes sensitivity value, «5» – manages anti-masking channel operation tactics, «2», «3», «4» supervise only the LED indication modes.

Table 2

DIP-switch	Position	Position	
		ON	OFF
«1» Sensitivity	Norm	High	
«2» TEST	Alarm LED Indication	Indication of detection	
«3» LED indication	ON	OFF	
«4» Alarm memory	ON	OFF	
«5» MASK	See Cl. 8.7		

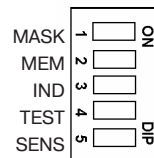

The Detector generates the following messages:

Table 3

Message	Contacts state			LED Indication	Indication Duration
	AL	TAMPER	FAILURE		
«Warm-Up Time»	Opened	Opened	Opened	Red 1 Hz	Up to 60 sec
«Norm»	Closed	Closed	Closed	OFF	
«Alarm»	Opened	Closed	Closed	Red	Not less than 2s
«Case tampering»	Closed	Opened	Closed	OFF	Up to cause removal
«Masking»	Closed	Opened	Closed	Blinking green	Up to cause removal
«Repositioning or wall tampering»	Closed	Opened	Closed	Blinking green	Up to cause removal
«Total lack of power supply»	Opened	Opened	Opened	OFF	Up to cause removal
«Voltage drop»	Closed	Closed	Opened	Green/Red	15 minutes <sup>1)</sup>
«Rise of ambient temperature»	Closed	Closed	Opened	Green/Red	15 minutes <sup>1)</sup>
«Self-testing procedure fail»	Closed	Closed	Opened	Green/Red	15 minutes <sup>1)</sup>
1) «Alarm memory» indication is switched ON with 5 minutes delay and is lighting during 15 minutes.					

## 8 Switching ON and Testing

8.1 During one minute after energizing the Detector with closed cover or after closing cover of already energized detector, the Detector operates in «Warm-up time» mode, after what it changes to standby mode and is ready to generate «Alarm» message.

8.2 «Alarm» message is generated by opening «AL» contacts for 4 sec after intrusion into detection zone.

8.3 During first seven minutes operation in standby mode the Detector displays crossing of every sensitivity zone by short-term blink (0.25 sec) of red LED indicator. This indication mode allows to check and adjust detection zone position. If «2» DIP-switch is set to «ON» position, LED indicator displays an «Alarm» message generation by lighting red during 4 sec.

8.4 After seven minutes operation in standby mode LED indicator displays an «Alarm» message generation by lighting red during 4 sec. To provide masking of the Detector operation, «Alarm» LED indication can be disabled by setting «3» switch to «OFF» position.

8.5 DIP-switch «1» changes the Detector sensitivity from normal («ON» position) to high («OFF» position). Detection range data in Cl. 3 are reported for the Detector normal sensitivity state.

### 8.6 Self-Testing

During process of its operation the Detector is monitoring power supply and ambient temperature values. Also it performs periodical procedure of detection channel self-testing. In case when ambient temperature reaches the value close to 36 °C, the Detector sensitivity level increases automatically.

If power supply reaches the value  $(62.5 \pm 2.5)$  °C or if self-testing procedure fails, the Detector generates relevant message by opening FAILURE contacts. This message is in progress during 15 minutes after removal of its cause, it is followed by LED indicator alternate lighting green and red.

## 8.7 Masking Detection

The Detector provides anti-masking function. «Masking» message is displayed by the LED indicator intermittent blinking green. If masking attributes remain constant, «Masking» message is generated by «AL» and «FAILURE» contacts opening. Masking message is generated not earlier than after three minutes upon the expiry of warmup time.

Depending on switch «5» position, anti-masking function is realised by two modes:

a) upon setting DIP-switch «5» to «OFF» position after every switching on the Detector stores current circumstances as an basic reference standard;

b) upon setting DIP-switch «5» to «ON» position the Detector refers to once-stored current circumstances as an basic reference standard.

Reference environment storage is fulfilled immediately after setting switch «5» to ON position. If the switch «5» is set to ON position while the Detector is in »Warm-up time« state with power off, then storage of reference environment is executed upon the expiry of »warm-up time«.

### 8.8 Detection of repositioning

The Detector controls changing of its tilt relatively to initial position for more than  $(5.5 \pm 0.5)^\circ$ . Storage of initial position is executed upon the expiry of «warm-up time».

## 9 Storage and Transportation

9.1 The Detector in original package without power supply batteries is resistant to:

a) transport jolting with the acceleration of 30 m/sec<sup>2</sup> with impact frequency rate from 10 to 120 impacts/sec or 15000 impacts with the same acceleration;

b) the ambient temperature from minus 50 ... +50 °C;

c) relative air humidity  $(95 \pm 3)$  % at the ambient temperature +35 °C.

9.2 The Detectors in original package may be transported by any transport facility in closed vehicles over any distances in compliance with the existing shipping rules concerning the respective means of transport.

9.3 After transportation under the conditions different to exploitation conditions, the Detector shall be ready to operate after a maximum of six hours.

## 10 Manufacturer's Guarantees

The Manufacturer guarantees conformity of the Detector to it's Technical Specifications if conditions of transportation, storage, assembling and operation are observed. The guaranteed storage period is 63 months since the date of manufacturing the Detector.

The guaranteed period of operation is 60 months since the date of commissioning within the storage period guaranteed.

The Detectors that are found to non-conforming to it's Technical Requirements shall be repaired by the Manufacturer, provided the installation and operation rules have been complied with.

## 11 Packing Certificate

Passive infrared vertical curtain detector «Foton-16B» has been manufactured in compliance with the active technical documentation and classified as fit for operation and packed by «RIELTA» JSC.

Packing date \_\_\_\_\_  
month, year